



# 700 Series

## CENTRIFUGAL SIFTER



Designed to meet high-capacity scalping and sifting for both large and small process applications, the Prater Rota-Sieve® proves its cost efficiency daily in the handling of a wide variety of powder, granules, agglomerates and other free-flowing materials.

The combination of high-centrifugal force and blade spreading action reduces binding problems, even when handling materials that tend to flake or agglomerate due to fat or moisture content.

Prater Rota-Sieves are ideal for removing foreign material (i.e. insects, plastic, string), sifting, scalping and classifying.

### FEATURES

- Stainless Steel Body
- Ultra high throughput
- Self-cleaning screens
- Three-bearing shaft support
- Adjustable 4-paddle rotor
- Quick in-place screen inspection
- Easier screen change and tensioning
- No vibration, dust or noise
- Optional patented Rota-Trap®
- Outboard discharge end bearing
- V-Belt drive
- Tool-less removal of rotor



### ADDITIONAL FEATURES

- “Quick-Take-Apart” Design
- Removable light-weight rotor assembly
- Fully welded one-piece body
- More screen area than competitive size units

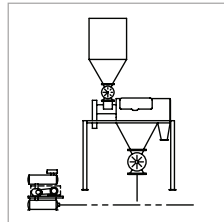

Sifting from bulk receiver prior to pneumatic transfer

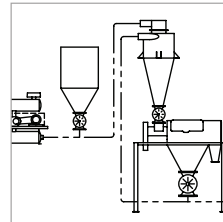

Inline sifting

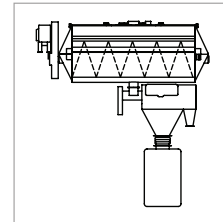

Sifting after blending prior to packing

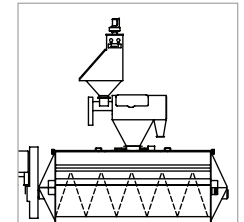

Sifting minor ingredients prior to blending

### APPLICATIONS

- Flour
- Sugar
- Bakery Mixes
- Chemicals
- Spices

### INDUSTRIES

- Food
- Chemical
- Mineral
- Powder Coatings
- Pharmaceutical

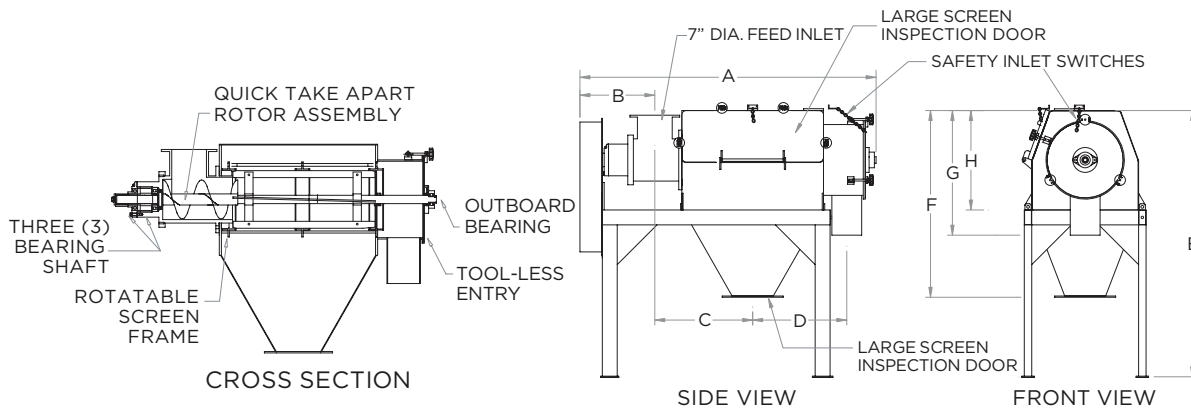
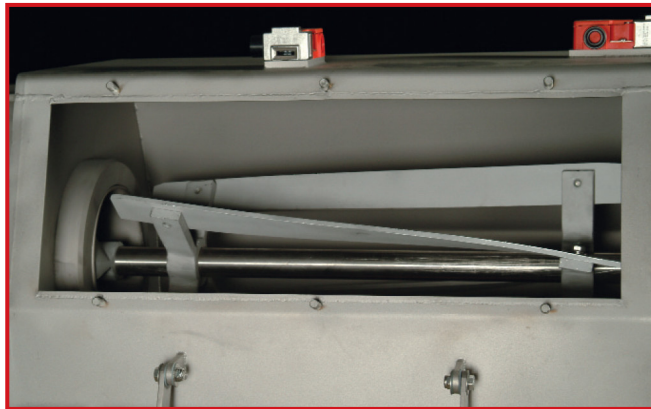

**DIMENSIONS IN INCHES\***

MODEL	EFFECTIVE SCREEN AREA	HP	MOTOR RPM	A	B	C	D	E	F	G	H
700	725 sq. in.	3	1800	59-9/16	15-1/16	9-11/16	18-15/16	55-1/2	37-19/32	25-1/16	20

\* Do not use for engineering purposes. Please request a certified drawing for all layout or construction uses.

**PRATER**<sup>®</sup>  
AIRLOCKS • MILLS • SEPARATORS

2 Sammons Court, Bolingbrook, IL 60440  
1-877-247-5625 • [praterindustries.com](http://praterindustries.com)