



Abrasion Resistant Rotary Airlock Valves

When Heavy-Duty Just Isn't Enough

Prater has your solution to airlocks that constantly wear out in high abrasive applications. For over 90 years, Prater Industries has manufactured thousands of airlocks for almost every free flowing dry material applications. Prater Airlocks are selected to feed material from a bin or hopper, to deliver fines from a collector while sealing against air loss and to feed material into a pneumatic conveying system against pressure or vacuum.

Prater's special treatment process allows Prater Abrasion Resistant Rotary Airlock Valves to withstand even the most abrasive applications, achieving better performance than airlocks made of cast iron, stainless steel, or Ni-hard. With less down-time, Prater Abrasion Resistant Rotary Airlock Valves reduce maintenance costs and help avoid losses in production, all the while achieving higher efficiency by holding our tighter tolerances longer.

Our Abrasion Resistant Rotary Airlock Valves boast a heavy cast iron housing with oversized mounting flange, Heavy-duty outboard bearings, self-adjusting packing glands (a Prater Exclusive), and pre-drilled end plates for air purge. Abrasion Resistant Rotary Airlock Valves options include, ceramic lined end plates, ceramic lined housings, and tungsten carbide throat.

SIGNIFICANTLY IMPROVES PERFORMANCE WITH:

- Aluminas
- Cement
- Clay
- Coke
- Carbon Black
- Coal
- Gypsum
- Limestone
- Flyash
- Pot Ash
- PVC Pellets
- Silica
- Stucco
- TiO2
- Zinc Oxide
- And many more!

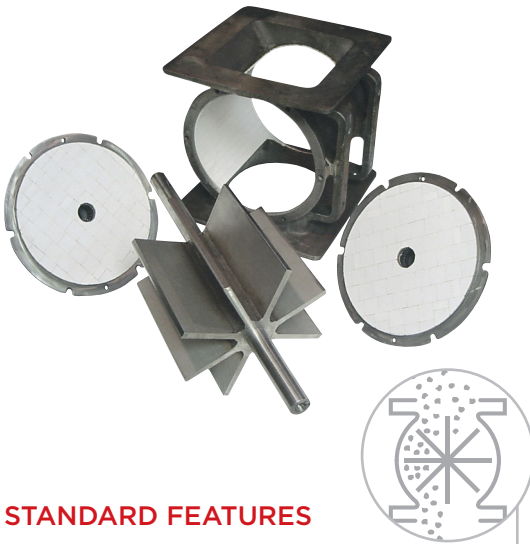

STANDARD FEATURES

- Cast-iron housing & end plates with abrasion resistant lining
- 8-blade rotor
- Universal flanges that match most existing bolt hole patterns
- 2 outboard bearings
- 2 self-adjusting packing glands



**THE ONLY AIRLOCK
IN NORTH AMERICA TO BE
TESTED & CERTIFIED
TO COMPLY WITH NFPA-69**

praterindustries.com

Longer Lasting With Greater Durability.

Prater offers an entire line of Abrasion Resistant Rotary Airlock Valves for a wide range of applications.

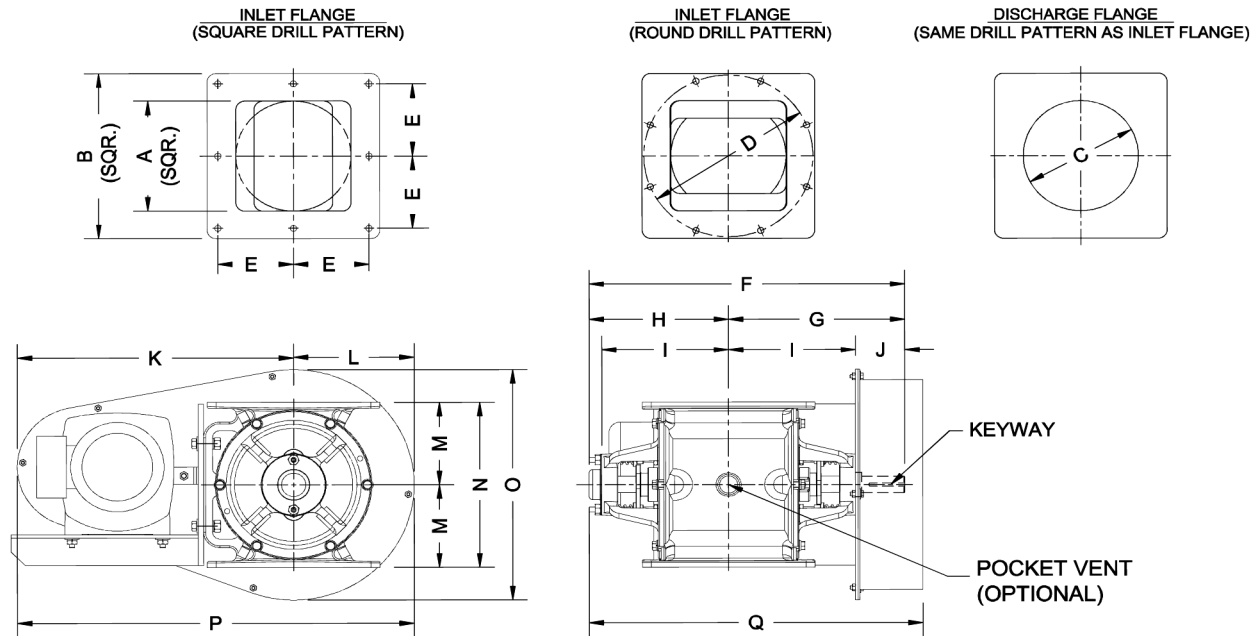

PRATER ABRASION RESISTANT ROTARY AIRLOCK VALVE SPECIFICATIONS

Considering an Abrasion Resistant Rotary Airlock Valve? Ask Yourself These Questions:

1. What is the particle size of the material to be handled?
2. What is the volume required per hour?
3. What is the bulk density of the material (lbs./cu. ft.)?
4. What is the operating temperature?
5. What is the differential pressure across the airlock?
6. Is the material abrasive, corrosive or sticky?

To Estimate Airlock Size:

To Estimate Airlock Size:

1. Calculate the volume rate per hour:
lbs./hr. ÷ Density(lbs./cu. ft.) = cu. ft./hr. of Product.
2. Log On to our Website to find the Airlock that meets your specifications.

MODEL	DISPLACEMENT (CU. FT./REV)	DIMENSIONS														HOLE (QTY)	KEYWAY W X D	DRIVE SHAFT DIA.	FLANGE THK.	WEIGHT (LBS)	WEIGHT W/ DRIVE (LBS)			
		A	B	C	D	E	F	G	H	I	J	K	L	M	N							O	P	Q
PAV-6 C/S	.15	6	10	6	9 1/2	4 5/16	19 3/8	10 11/16	8 11/16	7 13/16	2 1/2	19 1/4	8 3/8	5	10	16 3/4	27 1/4	21 1/16	8	1/4 x 1/8	1	5/16	70	145
PAV-8 C/S	.30	8	12	8	11 3/4	5 1/4	21 15/16	12 1/4	9 11/16	8 13/16	3	19 1/4	8 3/8	6	12	16 3/4	27 1/4	23 1/16	8	1/4 x 1/8	1 3/16	7/16	110	215
PAV-10 C/S	.53	10	15	10	14 1/4	6	25 3/16	14 1/8	11 1/16	10 1/8	3 1/2	19 1/4	8 3/8	7 1/2	15	16 3/4	27 1/4	25 3/4	8	3/8 x 3/16	1 7/16	1/2	230	325
PAV-12 C/S	.95	12	18	12	17	5 1/4	29 15/16	16 11/16	13 1/4	12	3 3/8	27 29/32	9 9/16	9 1/16	18 1/8	19 1/8	37 15/32	30 7/16	12 (S)	3/8 x 3/16	1 3/4	5/8	420	560

Abrasion Resistant Rotary Airlock Valves available in all sizes, including PAV-14, PAV-16, PAV-1420, PAV-1824 and PAV-2830. Contact Prater for technical drawings.

PRATER[®]
AIRLOCKS • MILLS • SEPARATORS

2 Sammons Court, Bolingbrook, IL 60440
1-877-AIRLOCK (247-5625) • praterindustries.com