

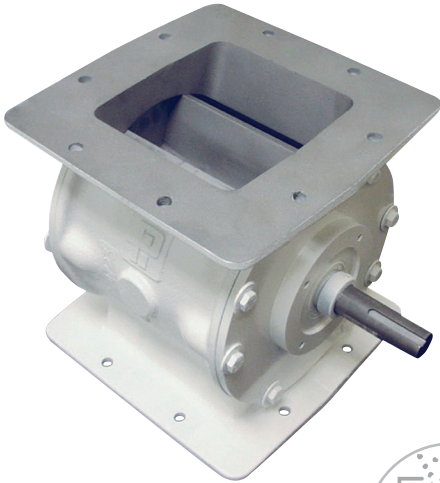

Rotary Airlock Feeder

DUST COLLECTOR SERIES



FEATURES

- Up to 300° F
- Up to +/- 3PSI pressure differential
- Cast iron construction
- Direct drive gear motor (29 RPM)
- Sizes: 6, 8, 10 and 12-inch square

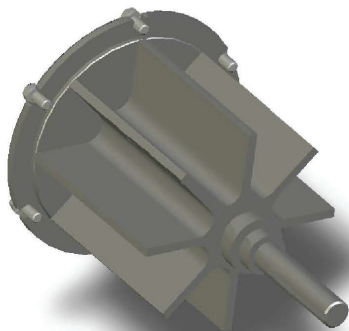

An economical, competitively priced valve suited for general use under dust collectors, cyclones and hoppers. With standard features most competitors call heavy-duty, all DCS airlocks boast eight-blade rotors, precision machining and rugged cast iron housings for efficient operation.

The Prater DCS airlocks can be configured for most application requirements. By manufacturing airlocks with larger pockets (up to 50% more volume) our airlocks can run at a lower speed. This provides the benefit of longer life, less maintenance and higher return on investment. Knowing that temperature plays a significant role in the operation of rotary airlock feeders, ALL Prater airlocks are carefully machined for actual opening temperature at no additional cost.

KEY BENEFITS

- Configurations available for quick shipment
- Easily retrofits into existing spaces

AVAILABLE OPTIONS

- **Beveled Rotor Tips** - Increases operating efficiency by minimizing drag and horsepower. Used with fine products that can smear or pack between the housing and rotor tips. The trailing edge of each blade is machined at a 15° angle, narrowing the land area.
- **Motion Switch** - A non-contact sensor that indicates loss of speed or zero speed, preventing damage to system components.
- **TEXP Motor** - For use in hazardous environments.
- **Flexible Rotor Tips** - For handling stringy or fibrous products that cause conventional rotors to jamb.

DCS	6	8	10	12
Capacity	0.15 cfr	0.3 cfr	0.525 cfr	0.95 cfr
HP	1/3	1/2	3/4	1
Approx. Weight	150 lbs	190 lbs	210 lbs	300 lbs

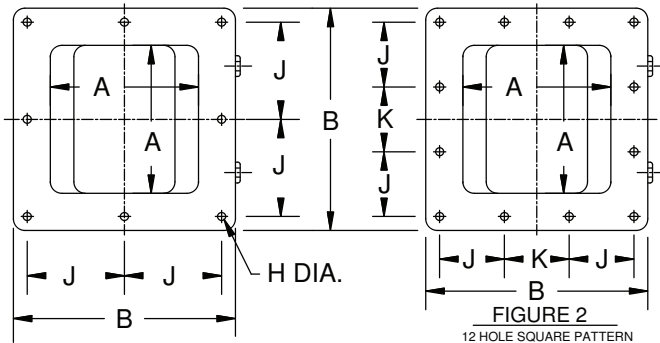
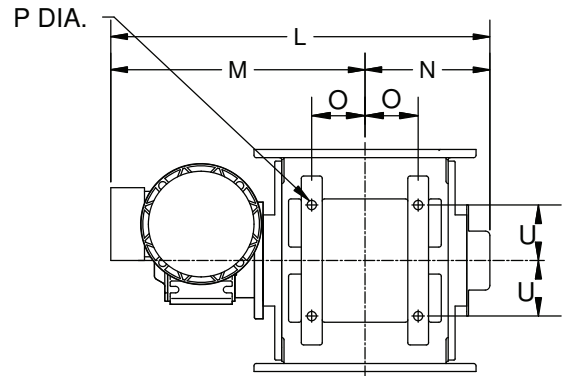
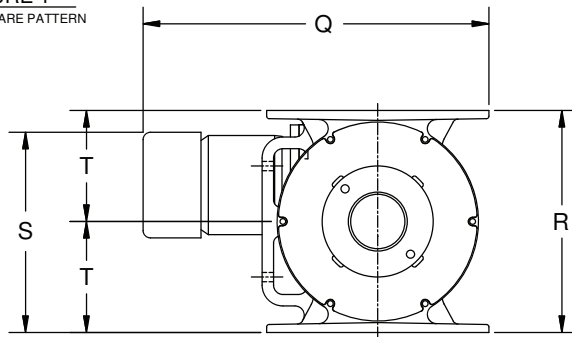
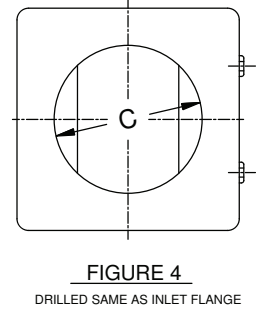
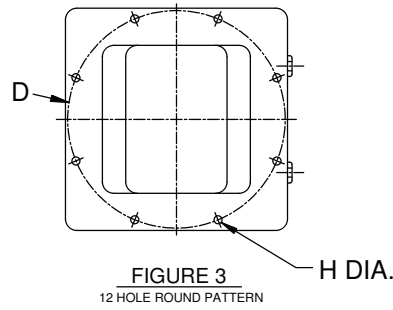

FIGURE 2
12 HOLE SQUARE PATTERN



MODEL	FLANGE FIGURE	A	B	C Dia.	D Dia.	H	HOLE QTY.	J	K	L	M	N	O	P	Q	R	S	T	U	FLANGE THK.	WT. lb. VALVE ONLY	MOTOR HP	VALVE SPEED RPM
DCS-6 C/S	1 or 3	6	10	6	9 1/2	7/16	8	4 5/16	N/A	16 13/16	11 7/16	5 3/8	2 1/4	1/2	17 5/8	10	9 7/16	5	2 1/2	5/16	90	1/3	29
DCS-8 C/S	1 or 3	8	12	8	11 3/4	7/16	8	5 1/4	N/A	20 1/2	13 3/4	6 3/4	2 7/8	1/2	18 11/16	12	10 13/16	6	3	7/16	110	1/2	29
DCS-10 C/S	1 or 3	10	15	10	14 1/4	7/16	8	6	N/A	22 11/16	14 5/8	8 1/16	3 1/4	1/2	21 13/16	15	13 1/4	7 1/2	4	1/2	165	3/4	29
DCS-12 C/S	2 or 3	12	18	12	17	7/16	12	5 1/8	5 1/4	26	16 1/4	9 3/4	3 1/2	7/8	23 3/4	18 1/8	14 13/16	9 1/16	5	5/8	373	1	29

PRATER[®]
AIRLOCKS • MILLS • SEPARATORS

2 Sammons Court, Bolingbrook, IL 60440
1-877-AIRLOCK (247-5625) • praterindustries.com