

PRATER SIGNATURE OPTIONS

HEAVY DUTY SERIES (C/S)

HD Construction and wide range of seals and venting options designed for use on pneumatic applications up to 12 PSI differential pressure



- Precision machined to actual operating temperature for a tight seal
- Outboard mounted, maintenance free bearings
- Abrasion resistant packing ring seals
- Convey line adaptors and pocket venting options

ABRASION RESISTANT SERIES

Long lasting construction for handling abrasive products, such as coke, fly ash, glass frit and minerals in both gravity feed and pneumatic applications

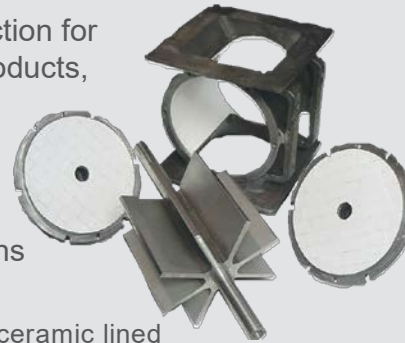

- Chrome, tungsten, or ceramic lined bodies
- Abrasion resistant (AR400) or tungsten lined rotor tips
- Custom side seals and air purging for longer shaft seal life

QUICK-TAKE-APART SERIES

Designed for applications that require frequent disassembly and cleaning

- Tool-less disassembly
- No re-gapping of rotor required when re-assembling
- Optional guide rail system to assist with part alignment and handling



BAV SERIES

Designed for easy cleaning and maintenance to limit down time

- VFD compatible direct drive
- Universal inlet & discharge flanges to fit a wide variety of applications.
- Compact low footprint design
- Optional food grade seals and finishes

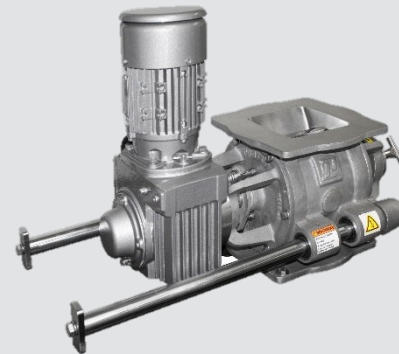

ROTARY AIRLOCKS

Perfectly Matched Performance

Capacity Chart

PRATER ROTARY AIRLOCK FEEDER (Capacity in Cubic Feet Per Minute)

RPM	10		15		20		25	
POCKET MODEL	FULL	80%	FULL	80%	FULL	80%	FULL	80%
PAV-6	1.50	1.20	2.25	1.80	3.00	2.40	3.75	3.00
PAV-8	3.00	2.40	4.50	3.60	6.00	4.80	7.50	6.00
PAV-10	5.25	4.20	7.95	6.30	10.50	8.40	13.12	10.50
PAV-12	9.50	7.60	14.75	11.40	19.00	15.20	23.75	19.00
PAV-14	14.75	11.80	22.20	17.70	29.60	23.60	36.88	29.50
PAV-16	23.00	18.40	34.50	27.60	46.00	36.80	57.50	46.00
PAV-1420	13.00	10.40	19.50	15.60	26.00	20.80	32.50	26.00
PAV-1824	30.00	24.00	45.00	36.00	60.00	48.00	75.00	60.00
PAV-2830	97.00	77.60	145.50	116.40	194.00	155.20	242.50	194.50

Note: When using as a feeder, run the airlock at 15 RPM or above.

PRATER SIGNATURE FEATURES

HOUSINGS

- Precision machined heavy duty castings offer long life and minimal air loss
- Oversized universal flanges allow our airlocks to match up to existing square or round bolt hole patterns
- Compact stack up height design allows for maximum material displacement in the smallest possible footprint

END PLATES

- Outboard mounted bearings for maximum strength and access
- Self adjusting packing glands offer maintenance free constant packing pressure
- Quick change packings - Allows a packing change without having to remove the end plate
- Sealed for life bearings gives maintenance free operation

ROTORS

- Precision welded and machined for the industry's tightest rotor to housing clearances
- Eight blade rotor design feeds smoother and maximizes the air seal design
- Abundant rotor construction and design combinations offer true custom designed solutions

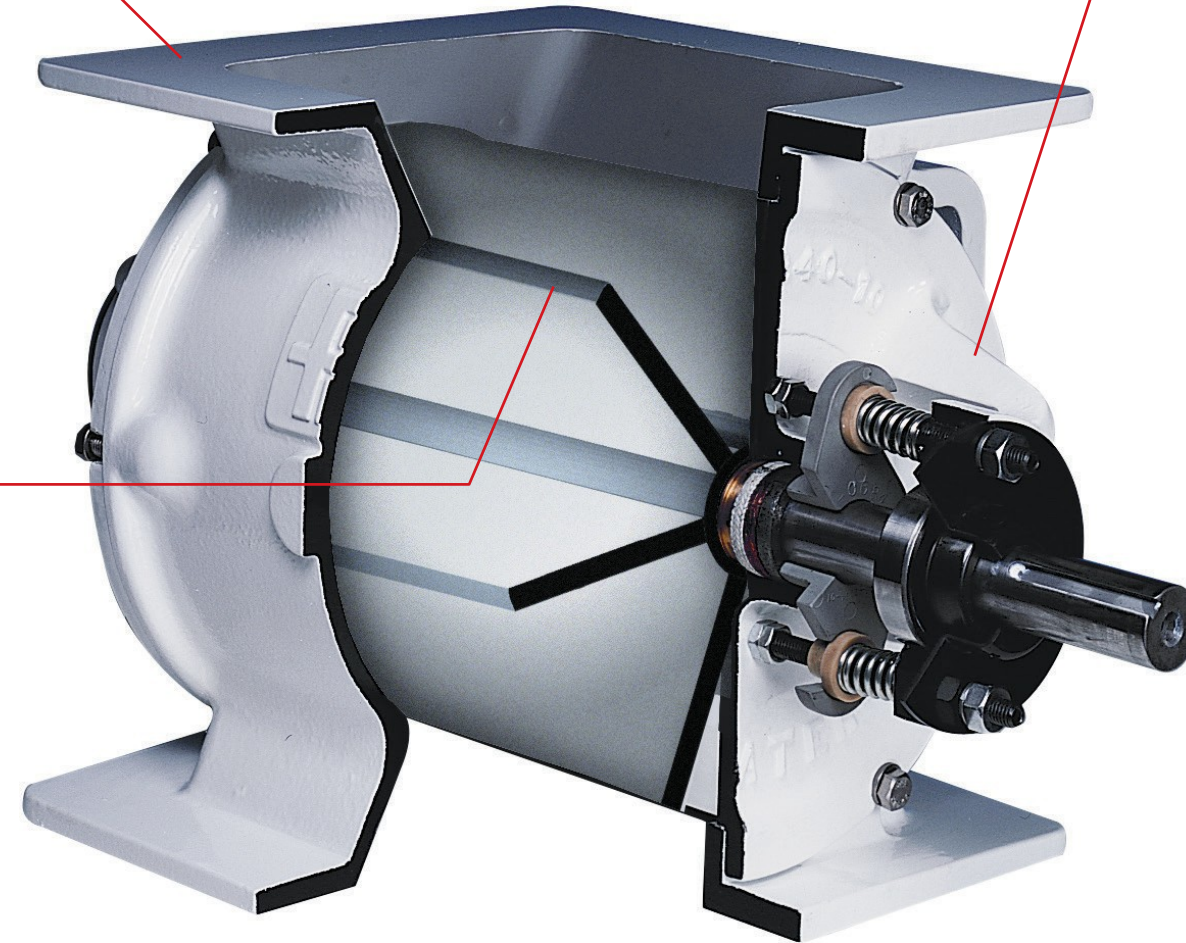

DRIVES

- Unicase housing design allows gearbox to run quieter and maximize oil, seal and bearing life
- Quadralip seal allows for maximum protection from contaminants
- Inverter duty rated motors rated for 5:1 constant torque

PRATER INDUSTRY CUSTOM SOLUTIONS

NFPA-69

Tested and Certified

- Body and rotor have sufficient strength to withstand pressure up to 32 psi
- Two vane edges seal each side of body at all times
- Design clearances of less than 0.0079"

MSHA

- Mine Safety and Health Administration - designed to meet with MSHA rules and regulations
- Our heavy duty valves out last the competition in these rugged applications

V- PLOW

- For smooth operation with pellet application
- Extends rotor and housing life
- Eliminates material from jamming the rotor

PSR 1 1

10 BAR EXPLOSION RESISTANT

- Designed and compliant with CSA-Z432-04 safeguarding of machinery

CSA

- Designed and compliant with CSA-Z432-04 safeguarding of machinery
- Canadian Standards Association

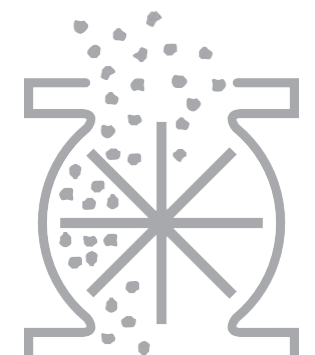

PRATER[®]
AIRLOCKS • MILLS • SEPARATORS

2 Sammons Court, Bolingbrook, IL 60440
1-877-AIRLOCK • praterindustries.com